

PUE 7 MEASURING INDICATOR



PUE 7 weighing indicators are intended for building industrial scales. It can be enclosed in a plastic or stainless steel housing for rack installations. It is equipped with a 5.7" colour graphic display with touch panel and membrane keypad. It also has installed two proximity detectors with programmable functionality.

Two platforms can be connected to the indicator. As regards peripherals, following devices can be connected: barcode scanners, receipt and label printers, transponder card readers and typical PC equipment (keyboard, mouse etc.). PUE 7 supports 1 weighing platform in standard version.

Accessible software versions:

- standard (functions of labelling, counting pieces, checkweighing),
- one-stand control of prepackages,
- mass comparator,
- network version of prepackages control (KTP NET),
- vibrating batcher.

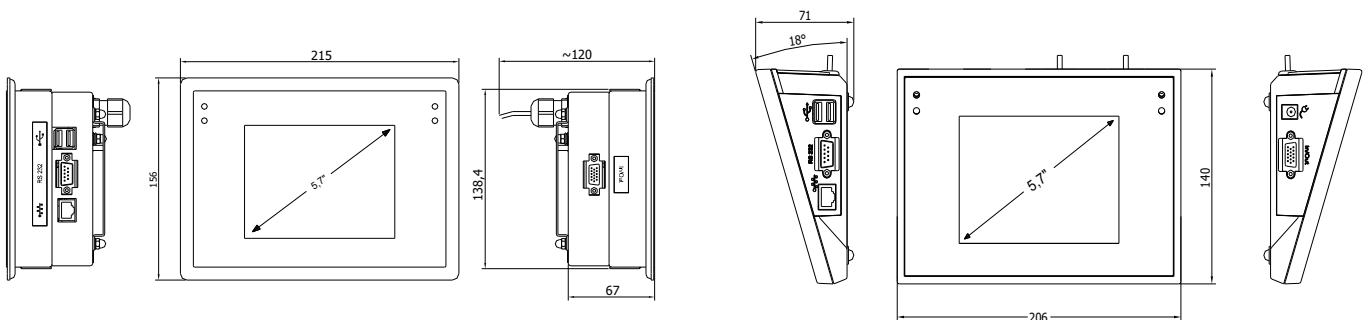

Infrared proximity sensors

Optional functions:

- PRINT function
- TARE function
- sensor's sensitivity adjustment

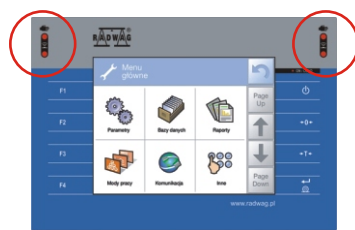

Interface communication

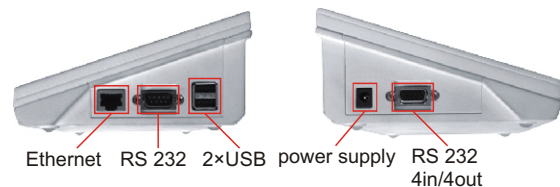

Technical data:

	PUE 7	PUE 7/P (panel)
Housing	plastic	stainless steel
IP rating	IP 54	front IP 66/67, whole IP 32
Proximity sensors	2	-
Power supply	120+230VAC; 10+15VDC	10+15VDC
Display	5,7" with touch panel	
Keypad	8 keys	
Operation Temperature	-10°C ÷ 40°C	
OIML class	III	
Maximum number of verification intervals	6 000	
Maximum input signal increase	19,5 mV	
Maximum voltage per verification interval	3,25 µV	
Minimum voltage per verification interval	0,5 µV	
Minimum tensometer impedance	80 Ω	
Maximum tensometer impedance	1200 Ω	
Tensometer bridge excitation voltage	5 V	
Processor	ARM 200 MHz	
Memory	RAM 64 MB, Flash 1 GB	
Operation System	Windows CE 6.0	
Number of platforms	2	4
Additional weighing platform module	Metrological parameters as in main platform (option)	
Interfaces	2×RS 232, 2×USB, Ethernet, 4in / 4out	

